

MF SERIES

STAINLESS STEEL HID FLOODLIGHT

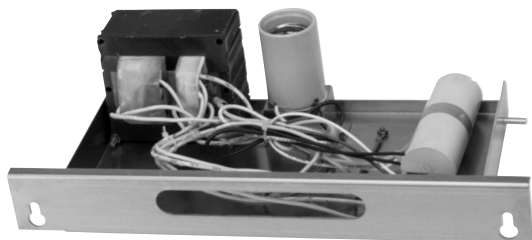

(MF-SS pictured)

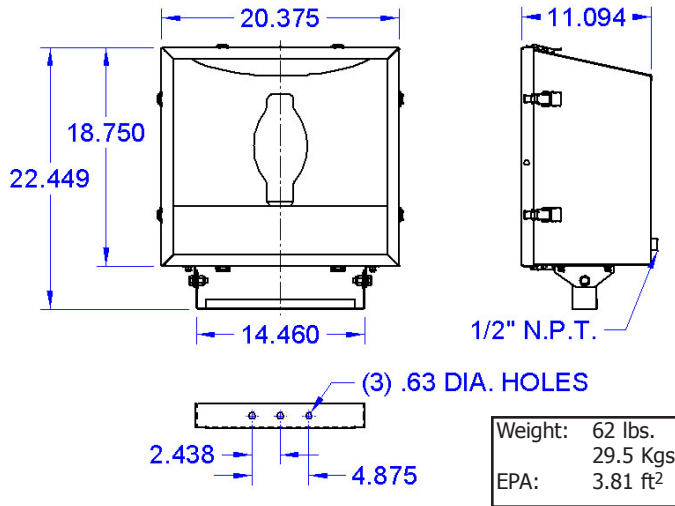

Ballast Tray removes from fixture for easy maintenance and lamp/ballast flexibility.

DESCRIPTION: The *MF Series* floodlight is an ideal fixture for marine applications where corrosion-resistant stainless steel construction and durability are demanded.

SPECIFICATIONS

• **HOUSING:**

316 type stainless steel for maximum durability and corrosion resistance in extreme marine applications.

• **LATCHES:**

Hinged, stainless steel, spring-loaded latches allow for easy access to lamp compartment. Latch locking feature ensures external seal and provides a watertight seal for internal component protection.

• **BALLAST TRAY:**

Ballast tray removes from fixture to allow for easy maintenance of ballast or interchange ballast type and wattage.

• **ADJUSTABLE DOOR ASSEMBLY:**

Field selectable latch set serves a dual role as both latch and hinge, allowing the door to be opened in any preferred direction.

• **LENS:**

Tempered glass lens to resist heat and thermal shock.

• **GASKET:**

Single-piece silicone gasket for watertight seal.

• **REFLECTOR:**

Semi specular reflector for efficient uniform performance.

• **OPTIONS:**

Available with pole mount for fixed installation. Electro-Polish option available.

COMPLIANCES

UL Listed- 1598A Marine Outside Type
(Saltwater)

cUL Listed
IP66

USCG Accepted



PHOENIX®

PHOTOMETRICS

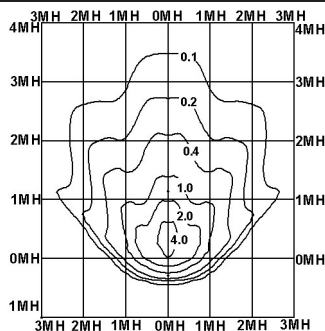

MF400HPS

400W High Pressure Sodium (ED-18)
 NEMA Type: 6x6
 Lumens: 50000
 Mounting Height = 40'

For mounting heights (MH) other than 40' use:

$$\left(\frac{40}{\text{Actual Height}}\right)^2 \times \text{FC chart value}$$

For lamp watts other than shown in chart use:

$$\left(\frac{\text{Actual Lumens}}{\text{Lamp Lumens}^*}\right) \times \text{FC chart value}$$

* MH = 36000
 HPS = 50000

ORDERING INFORMATION

ITEM A - HOUSING

Customer must order Item A and Item B for a complete fixture

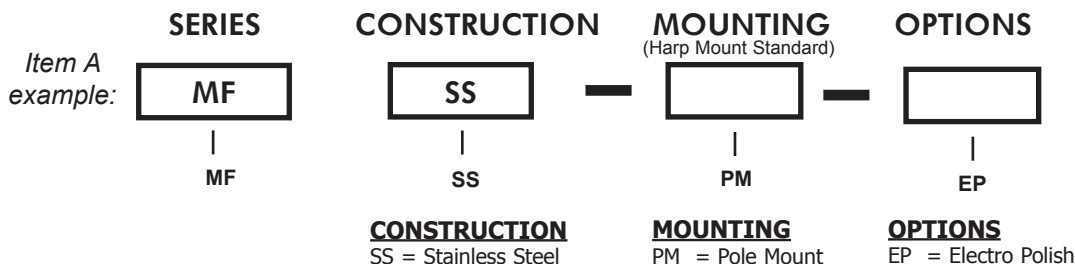

ITEM B - BALLAST TRAY

Customer must order Item A and Item B for a complete fixture

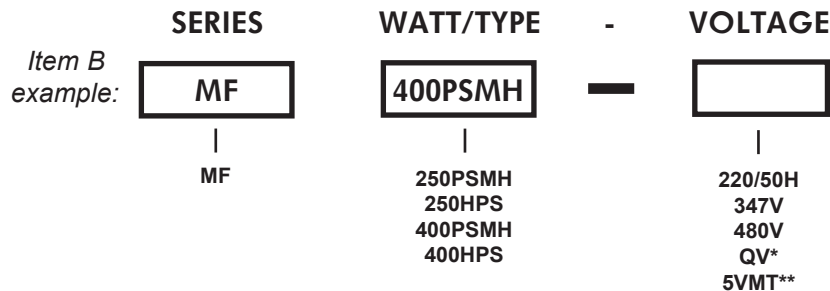

WATT/TYPE (lamp NOT included)

250PSMH = 250 watt Pulse Start Metal Halide (ED-28)
 400PSMH = 400 watt Pulse Start Metal Halide (BT-37)
 250HPS = 250 watt High Pressure Sodium (ED-18)
 400HPS = 400 watt High Pressure Sodium (ED-18)

VOLTAGE OPTIONS

220/50H = 220 Volt, 50Hz
 347V = 347 Volt
 480V = 480 Volt
 QV* = 120, 208, 220, 277 Volt
 5VMT** = 120, 208, 220, 277, 480 Volt

* QV is standard on HPS models unless otherwise specified.
 ** 5VMT is standard on PSMH models unless otherwise specified.

ACCESSORIES

Not Shown

QSK = Quartz Standby
 IEF = Single Fuse (120, 277V)
 DIEF = Dual Fuse (208, 240, 480V)
 PK = Photo Cell (up to 400W)

N5610162C

PHOENIX®