

LFSB SERIES

Snaplight® Fluorescent



shipping weight is 8.66 lbs. (3.93 kg)

2 ft. LFSB

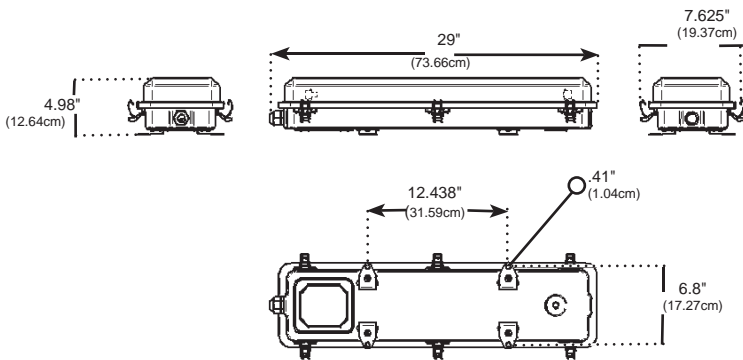

shipping weight is 13.44 lbs. (6.10 kg)

4 ft. LFSB

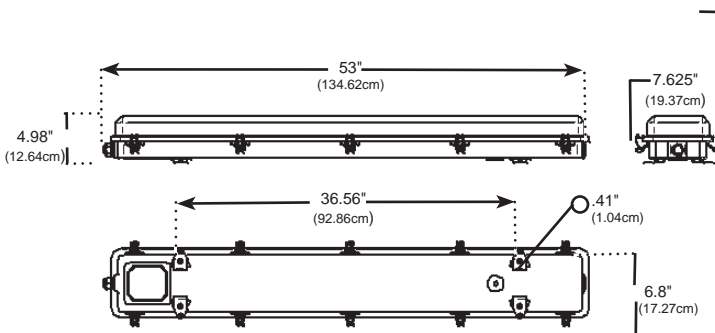

DESCRIPTION: The *LFSB Series* is a marine rated, surface-mounted fluorescent ceiling fixture. Available in two or four foot lengths.

SPECIFICATIONS

Housing: Corrosion free high impact glass reinforced, UV stabilized nylon. Superior cold temperature impact strength.

Diffuser: High impact polycarbonate matte finish. Tethered to housing for easy relamping; merely unlatch and change lamp.

Gasketing: Watertight gasket attached to lens provides positive seal against moisture and dirt.

Hardware: All external hardware is captive and non-magnetic stainless steel.

Ballast: 120V, 60Hz, high power factor, Class P ballast standard. Alternative voltages available.

Reflector: Tethered to housing for ease of maintenance. Thermoset high reflectance, white polyester powder coated finish.

Internal Fasteners: Unique captive quarter-turn fasteners secure reflector - no need to worry about losing screws or washers while installing or servicing fixture. No tools required.

Lamp Holders: Vibration resistant spring loaded lamp holders standard.

Conduit Openings: 3/4" NPT threaded on both ends. Threaded plug and cable gland provided.

Mounting Feet: Standard heavy duty shock resistant stainless steel mounting feet.

Compatibility: Interchangeable with existing installations of similar light fixtures from other manufacturers.

Wiring: Additional circuit thru wiring is standard. (max two lamp 40W)

OPTIONS

- Emergency ballast battery type
- Electronic ballast
- Low-temperature ballast
- Dimmable ballast
- Terminal block
- Colored lamp sleeves
- WT- Marine Outside Type Saltwater

COMPLIANCES

UL 1598A Listed - Marine Outside Type Saltwater (WT option)

UL 1598A Listed - Marine Type Electric Fixture Inside Dripproof Type

UL 1598 Listed - Wet Location

UL 924 Listed - Emergency Ballast

Meets US Coast Guard Requirements

ABS

IP65 (WT option)



PHOENIX®

PHOTOMETRICS

Contact Phoenix Products Company for Photometric Information.
Or visit our Website at www.phoenixproducts.com

ORDERING INFORMATION

*** PLEASE NOTE: NOT ALL COMBINATIONS LISTED BELOW ARE AVAILABLE. CONTACT FACTORY WITH ANY QUESTIONS

SERIES	LAMP QTY	WATT/TYPE	OPTIONS			
			VOLTAGE (120V Standard)	HERTZ (60Hz standard)	ELECTRICAL	OTHER
LFSB	2	17	120	50Hz	EMB	RM
LFSB	1	17	120	50Hz	EMB	RM
	2	20	208	60Hz	TB	WT
	3*	32	220		RFF	
		35	240		IF**	
		40	277		ELB***	
		54	347		LTB	
		60	12		DIM	
			24		DB	
			UNIV			

LAMP QUANTITY

- 1 = 1 lamp
- 2 = 2 lamps
- 3 = 3 lamps*

* Not available on 35 or 60 watt fixtures.

WATT/TYPE (Base / fixture length) (lamps not included)

- 17 = F17 T-8 (Med Bi-pin, 2')
- 20 = F20 T-12 (Med Bi-pin, 2')
- 32 = F32 T-8 (Med Bi-pin, 4')
- 35 = F24 T-12HO (RDC, 2')
- 40 = F40 T-12/SP41 (Med Bi-pin, 4')
- 54 = F54T5HO (Mini Bi-pin, 4')
- 60 = F48T-12HO (RDC, 4')

VOLTAGE OPTIONS

- (120V Standard)
- 120V = 120 Volt
- 208V = 208 Volt
- 220V = 220 Volt
- 240V = 240 Volt
- 277V = 277 Volt
- 347V = 347 Volt
- UNIV = Universal voltages (120-277V; 50/60Hz)
- 12V = 12 Volt
- 24V = 24 Volt

ELECTRICAL OPTIONS

- EMB = Emergency Battery Backup
- TB = Terminal Block
- RFF = Radio Frequency Filter
- IF = In-line Internal Fuse**
- ELB = Electronic Ballast***
- LTB = Low Temperature Ballast
- DIM = Dimmable Ballast
- DB = Dual Ballast

** Not available on marine listed fixtures

*** Electronic Ballast standard on all fixtures except 20W

ACCESSORIES

Ordered separately for field installation

COLORED LAMP SLEEVES

Color	Length	Phoenix Part No.
Red	2'	7259100
Red	4'	7550039
Green	2'	contact factory
Green	4'	7550040
Blue	2'	4055010
Blue	4'	7550264

OTHER OPTIONS

- RM = Rigid Mount
- WT = UL1598A Listed - Marine Outside Type Saltwater

PHOENIX®

N5610955D