

# PHOENIX MODULAR LED DOCKLITE®

## LED LOADING DOCK LIGHT HEAD

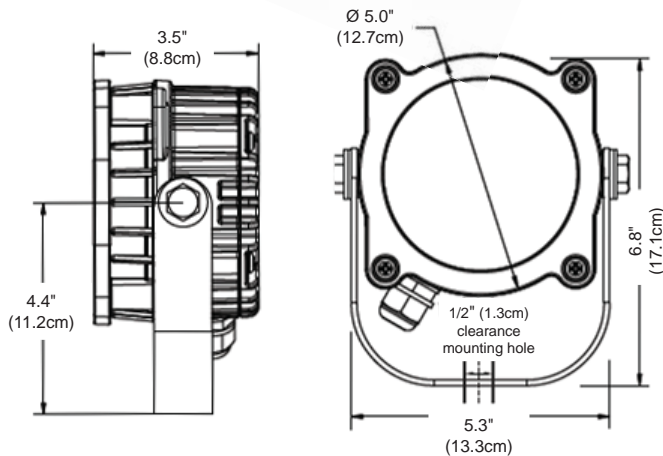

Packaged weight: 5.4lbs (2.4kg)  
 Fixture weight: 4.7lbs (2.1kg)

**DESCRIPTION:** Modular LED *docklite*® head handily delivers instant-on, bright, and uniform light, easily illuminating the full length of truck trailers. The LED head retrofits easily to installed dock light arms of nearly any brand. Powered by only 16W, the LED *docklite*® is much more energy efficient than the standard incandescent head using a 150W lamp. With no filament to break, the LED head is also extremely durable and far more likely to survive an accidental impact.

## SPECIFICATIONS

**Housing:** Durable cast aluminum housing in safety yellow powder coat finish for maximum visibility. Small size minimizes potential for accidental impact. Housing remains cool to the touch during operation.

**Light Source:** Light emitting diodes (LED) with 50,000 hours average rated life. 15° beam angle.

**Lens:** Impact resistant clear acrylic (no glass)

**Performance:** Uniformly delivers over six footcandles to the nose of a 53' trailer. Operating on only 16W, the LED head offers an 89% energy savings over an incandescent dock light with a 150W lamp. Minimum starting temperature: -30° C. Maximum operating temperature: 40° C. Contact factory for photometric data.

**Mounting Bracket:** Steel bracket with 1/2" (1.3cm) clearance hole allows for easy retrofit with almost any existing dock arm.

**Electrical:** 16W, 100V-240V, 50-60Hz. 22" (55.8cm) cord with recessed 3-prong IEC type (C-14) plug fits into the receptacle of almost any existing dock light arm.

## ORDERING INFORMATION

### LIGHT HEAD

	SERIES	WATT/TYPE	PART
Example:	DL	16LED	LH
	DL	16LED	LH

### ARMS

	SERIES	LENGTH	PART
Example:	DL	24	ARM
	DL	24" 42" 60"	ARM

**Note:** Modular arms, used with the LED head, are only available in 120V.  
 Please see the Modular *docklite*® specification sheet for details.

## 3 YEAR WARRANTY

A three-year limited warranty against defects in material and workmanship is standard on all *docklite*® finished goods. See Standard Terms and Conditions for details.

## COMPLIANCES

UL 153 Listed: Portable Work Lights  
 Suitable for Wet Locations  
 (Wet location use requires appropriate receptacle. See installation instructions.)



IP65

**docklite**®

N5499786C

**PHOENIX**®  
*Durability by Design*

8711 West Port Avenue • Milwaukee, WI 53224 USA • Phone: 414.973.3300 • Fax: 414.973.3210  
 www.phoenixproducts.com