

PENDANT MOUNT KIT



General: The Pendant Mount Kit is used in conjunction with Intrigue luminaires allowing the fixtures to hang from rigid surfaces like overhanging roofs, under canopies, entryways and passageways. The ball-type mounting plate swivels permitting the fixture to hang straight.

Construction: Zinc plated steel mounting plate with aluminum ball-type swivel. Threaded steel conduit ($\frac{1}{2}$ " pendant stem).

Mounting: Ball-type mounting plate has a 20° swivel from vertical allowing luminaire to hang straight down from mounting surface. Mounting plate fits over standard 3-1/4" or 4" octagonal junction box. Pendant Mount Kits supports up to 50 lbs. (22.5 kg). Wiring from primary source to fixture provided by other (connection made at fixture).

Pendant Length: Three standard pendant lengths available: 12", 24" and 48" (30.5 cm, 61 cm and 121.9 cm). For custom lengths, please choose the CL(*) length option and specify the length in inches. See Order Information (Page 2).

Finish: Textured polyester powder coat finish. Mounting plate, swivel ball and stem standard in black. Bronze, gray, white, silver and verde green options available. For custom colors, please contact factory.

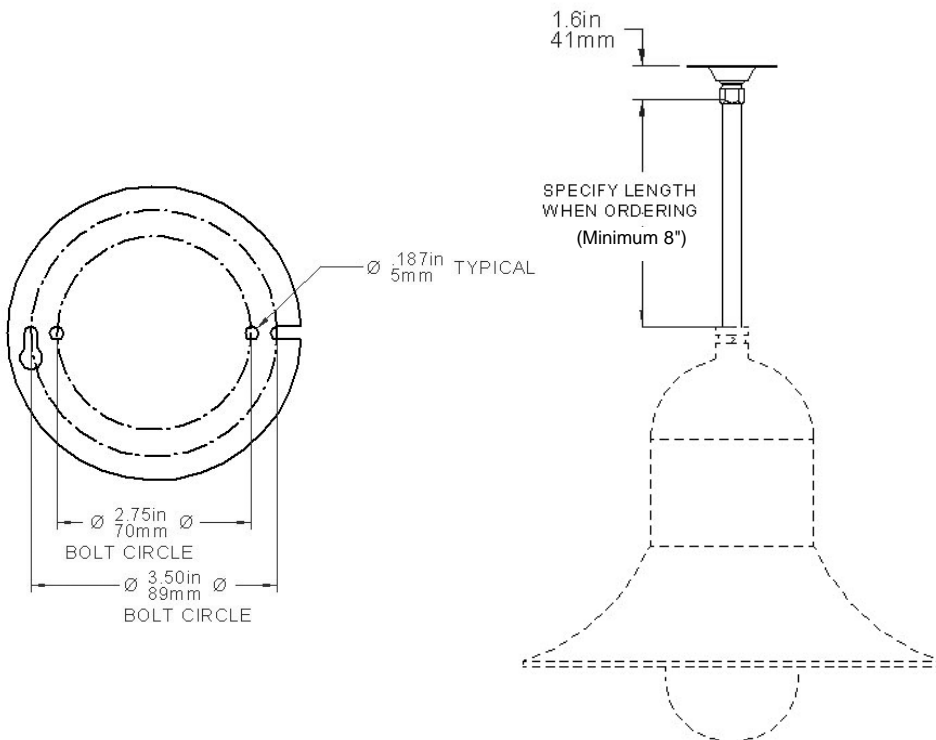

SEE SEPARATE SPECIFICATION SHEETS FOR INTRIGUE PENDANT MOUNT FIXTURES (Citation, Large Concord, Elegant, Epic, Large Metro and Mystique).

PHOENIX
Intrigue
SERIES™

ORDERING INFORMATION

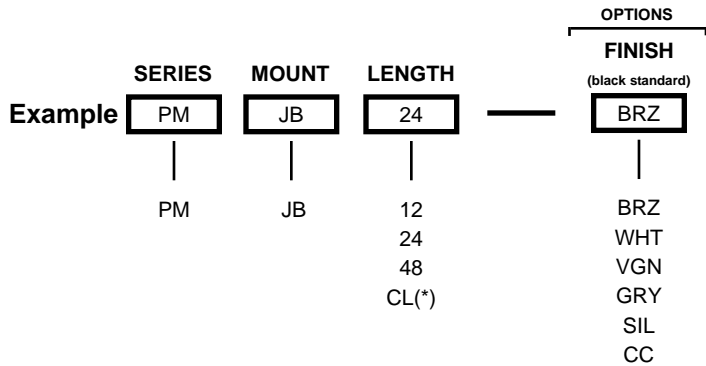

Mounting

JB = Junction Box Mounting
(3¼" and 4" Octagonal Boxes)

Length

12 = 12"
24 = 24"
48 = 48"
CL(*) = Custom Length (* = specify length in inches, 8" minimum)

Finish (Black Standard)

BRZ = Bronze
WHT = White
VGN = Verde Green
GRY = Gray
SIL = Silver
CC = Custom Colors
(contact factory)

