

# SOLITAIRE SERIES

## SURFACE MOUNT WALL PACK



3-Stripe Guard



Dual Cross Guard



Half Cutoff



Half Cutoff with Guard



Open Face



Single Cross Guard

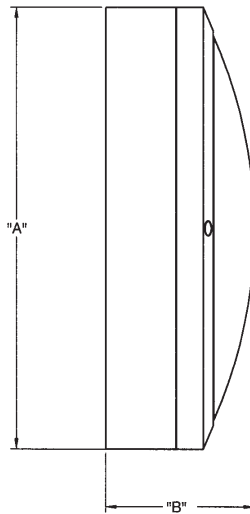
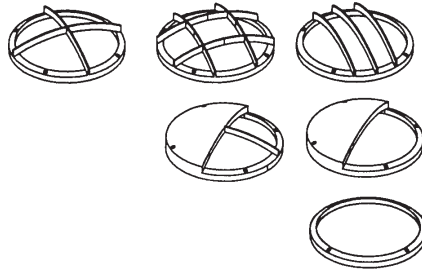

FRAME STYLE	DIM "A"	DIM "B"
3-Stripe Guard	10.47" (265.9mm)	4.24" (107.7mm)
Dual Cross Guard	10.47" (265.9mm)	4.24" (107.7mm)
Half Cutoff	10.47" (265.9mm)	4.24" (107.7mm)
Half Cutoff with Guard	10.47" (265.9mm)	4.24" (107.7mm)
Open Face	10.47" (265.9mm)	3.51" (89.2mm)
Single Cross Guard	10.47" (265.9mm)	4.24" (107.7mm)

**General:** The Solitaire Series Surface Mount Wall Pack is perfect for areas where good illumination in a decorative package is desired.

**Construction:** Rugged copper-free cast aluminum housing and face frame. All external hardware is stainless steel for protection against corrosion.

**Lens:** Opal polycarbonate lens is standard.

**Lamps:** Lamps included. Accepts 13W and 18W compact fluorescent lamps (twin tube).

**Ballast:** Integral ballast mounted to reflector bracket for easy maintenance. Compact fluorescent units standard with universal 120-277V, 50/60HZ electronic ballast.

**Finish:** Textured polyester powder coat finish. White reflector on all fixtures. Black housing and face frames standard. Bronze, gray, white, silver, and verde green options available. For custom colors, please contact factory.

**Gaskets:** EPDM gasket standard.

**Frame:** Six frame styles available: 3-stripe guard, dual cross guard, half cutoff, half cutoff with guard, open face and single cross guard.

**Mounting:** Surface or ceiling mount using predrilled holes to connect over junction box.

**Listings:** UL Listed 1598 for Wet Locations and ADA compliant for open face option.



# PHOTOMETRICS



3-Stripe Guard

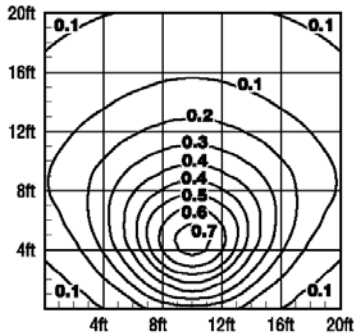

**SLS18CFL3SG**  
18W Compact Fluorescent  
6' Mounting Height

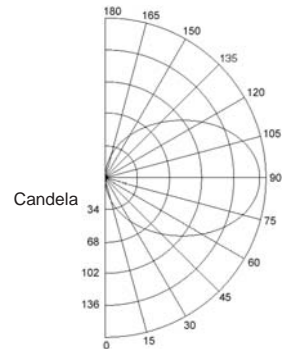

**SLS18CFL3SG**  
18W Compact Fluorescent  
NEMA Type: 7x7  
Lumens - 1200



Dual Cross Guard

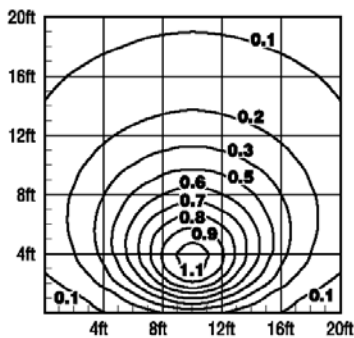

**SLS18CFLDCG**  
18W Compact Fluorescent  
6' Mounting Height

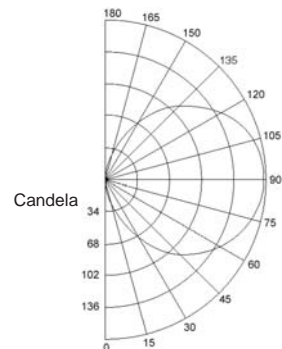

**SLS18CFLDCG**  
18W Compact Fluorescent  
NEMA Type: 7x7  
Lumens - 1200



Half Cutoff

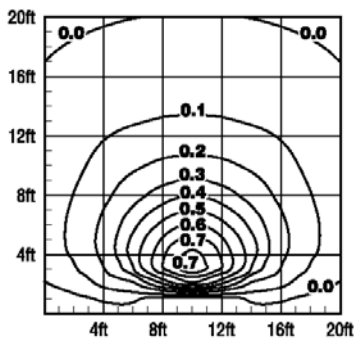

**SLS18CFLHC**  
18W Compact Fluorescent  
6' Mounting Height

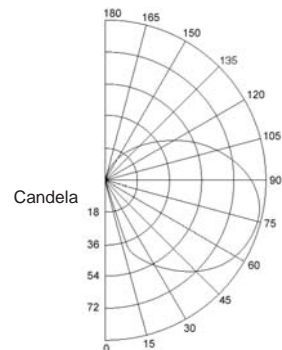

**SLS18CFLHC**  
18W Compact Fluorescent  
NEMA Type: 7x6  
Lumens - 1200

# PHOTOMETRICS



Half Cutoff with Guard

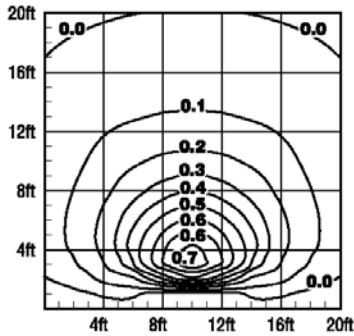

**SLS18CFLHCG**  
18W Compact Fluorescent  
6' Mounting Height

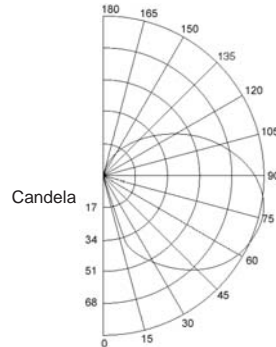

**SLS18CFLHCG**  
18W Compact Fluorescent  
NEMA Type: 7x6  
Lumens - 1200



Open Face

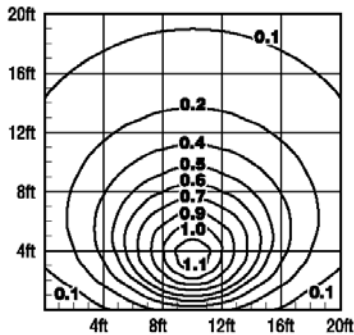

**SLS18CFLOF**  
18W Compact Fluorescent  
6' Mounting Height

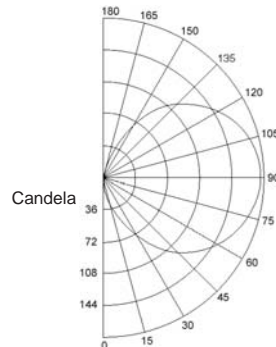

**SLS18CFLOF**  
18W Compact Fluorescent  
NEMA Type: 7x7  
Lumens - 1200



Single Cross Guard

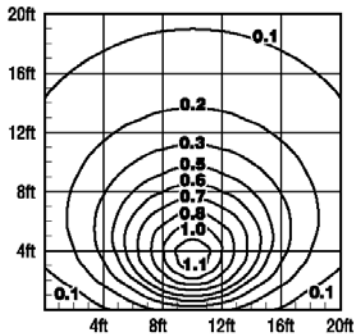

**SLS18CFLSCG**  
18W Compact Fluorescent  
6' Mounting Height

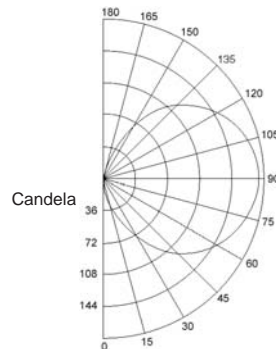

**SLS18CFLSCG**  
18W Compact Fluorescent  
NEMA Type: 7x7  
Lumens - 1200

# ORDERING INFORMATION

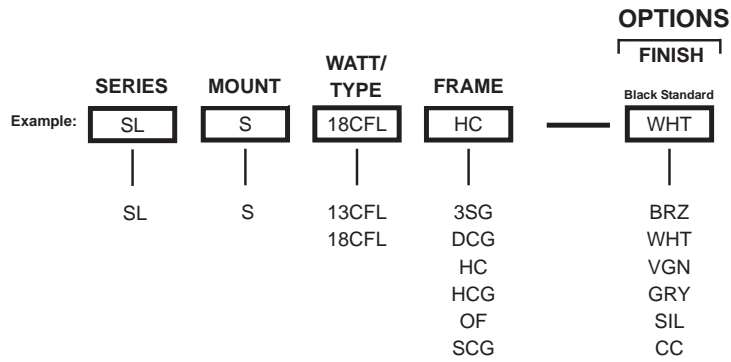

## Mounting

S = Surface

## Lamp Wattage/Type

13CFL = 13W Compact Fluorescent (twin, 4-pin)

18CFL = 18W Compact Fluorescent (twin, 4-pin)

## Frame

3SG = 3-Stripe Guard

DCG = Dual Cross Guard

HC = Half Cutoff

HCG = Half Cutoff with Guard

OF = Open Face

SCG = Single Cross Guard

## Finish (Black Standard)

BRZ = Bronze

WHT = White

VGN = Verde Green

GRY = Gray

SIL = Silver

CC = Custom Colors (consult factory)

N5610337C

PHOENIX  
*Intrigue*  
SERIES™